

CUSTOM Xi™ SERIES HEAVY DUTY COMMERCIAL ELECTRIC WATER HEATERS

ADVANCED ELECTRONIC CONTROL

- A. O. Smith's new proprietary electronic water heater control, provides precise + or - 1° temperature control, that is ideal for industrial and food service applications where exact temperatures of hot water are needed.
- The Operating Set Point is adjustable from 90°F/42°C to 190°F/88°C. The factory setting is 120°F/49°C.
- Approved for 180°F/82°C sanitizing applications.

PLAIN ENGLISH TEXT

- Animated icons display detailed operational and diagnostic information. Fault or Alert messages appear if an operational issue occurs.

ELEMENT SENSING

- Each element is constantly monitored and current on/off state is displayed, any element failure is reported and it's exact location is shown, eliminates a need for field testing of elements.

LOW WATER CUT OFF

- Factory standard on board low water cutoff uses a remote electric immersion type probe to prevent energizing of the elements in the event of low water condition and eliminates accidental dry firing.

SEQUENCING

- Units with multiple element contactors are sequenced on with one-second delay between stages. Prevents high amp electrical loads from hitting the electric system all at once and provides a smoother operating unit. Adjustable modulating mode is optional see options.

NIGHT SETBACK OPERATION

- Control system automatically lowers the operating set point by a user defined value during setback periods. Seven-day clock may be programmed for night set back and or weekend shutdown to reduce operating cost and save energy.

BUILDING MANAGEMENT SYSTEM

- BACnet or Modbus compatible with optional ICC Gateway.

ICOMM™ COMPATIBLE

- Call 1.888.WATER02 for more information.

POWERED ANODE

- The DSE models use a unique combination of a conventional magnesium anode and a European style power anode. The powered anode is self-adjusting to water conditions, does not require maintenance unless damaged, and provides longer-lasting tank protection in hard to reach areas. This multi-anode system provides superior anodic protection to hidden surfaces of the tank not protected in convention commercial electric water heaters.

INCOLOY IMMERSION HEATERS

- Heavy-duty medium watt density elements have incoloy sheathing and prewired leads: provides excellent protection against oxidation and scaling. Input ranges from 3kW to 90kW available (see accompanying chart). Rugged, industrial grade, flanged, bolt in style elements.

HEAVY FOAM INSULATED

- All models meet or exceed the thermal efficiency and/or standby loss requirements of the U. S. Department of Energy and current edition ASHRAE/IESNA 90.1.

GLASSLINED TANK

- A. O. Smith's PermaGlas® coating provides truly superior protection against corrosion and is permanently bonded to all inner tank surfaces at 1600°F.

ASME TANK CONSTRUCTION

- 125 psi working pressure (65 thru 120 gallons), 150 psi working pressure (5 thru 50 gallons).

THREE YEAR LIMITED WARRANTY

- For complete warranty information consult written warranty.

Features and benefits continued on the following page.



DSE-5 thru DSE-120 (DSE-100 Shown)



FEATURES AND BENEFITS (CONTINUED)

STANDARD VOLTAGES

- 208, 240 and 480 volt single and three phase. Single phase 208 and 240 are convertible to three phase. All 208 and 240 volt at 24kW and below are supplied phase convertible (single to three and vice versa). 277 volt single phase also available. Consult factory for 120 volt power circuit availability.

TERMINAL BLOCK

- To accept copper or aluminum leads (on units with more than one contactor).

120 VOLT CONTROL CIRCUIT

*Powered by fused transformer.

MAGNETIC CONTACTORS

- Heavy-duty UL rated for 100,000 cycles.

POWER CIRCUIT FUSING (120 AMP CURRENT DRAW AND ABOVE)

- Meets National Electric Code and UL requirements that water heaters must have internal fusing when current draw exceeds 120 amps.

SIMPLIFIED CIRCUITRY, COLOR-CODED FOR EASE OF SERVICE

BRASS DRAIN VALVE

HINGED CONTROL COMPARTMENT DOOR

CSA CERTIFIED AND ASME RATED T&P RELIEF VALVE

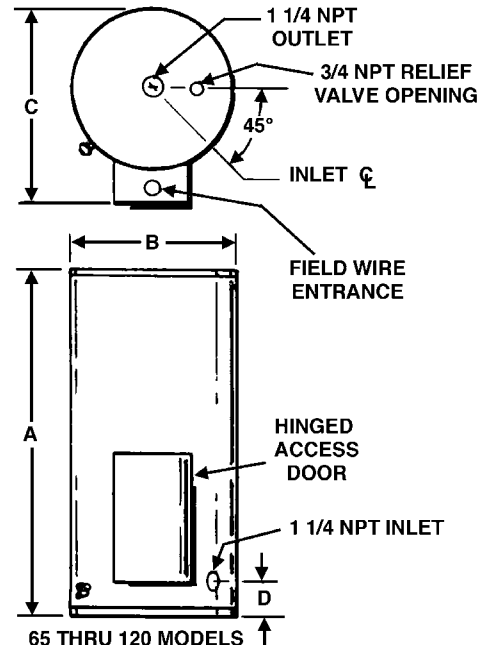
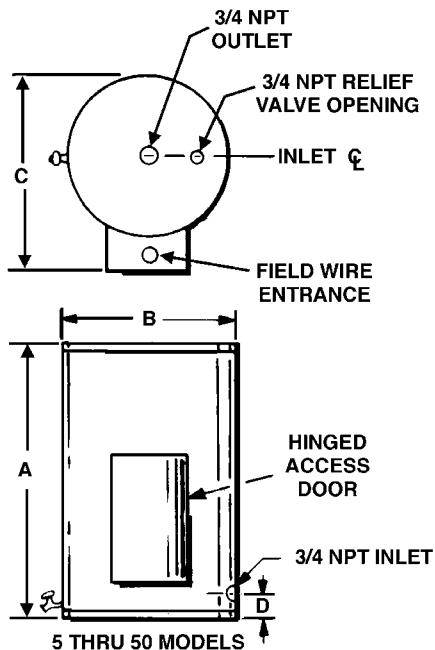

ROUGH-IN DIMENSIONS

Model Number	Tank Capacity		Maximum kW Input	Dimensions in Inches (mm)								Approx. Shipping Weight	
	Gallons	Litres		A	B	C	D	lbs.	Kg.				
DSE-5	5	19	3	20-1/4	521 mm	16-1/4	412.75 mm	22-1/2	571.5 mm	5-1/4	133.35 mm	82	37.2
DSE-10	10	38	6	26-1/4	667 mm	18-3/4	476.25 mm	25	635 mm	5-1/4	133.35 mm	116	48.1
DSE-20	20	76	18	27-1/4	692 mm	20-1/2	520.7 mm	26-1/2	673.1 mm	5-3/4	146.05 mm	145	65.7
DSE-30	30	114	24	35-3/4	908 mm	20-1/2	520.7 mm	26-1/2	673.1 mm	5-3/4	146.05 mm	150	68.0
DSE-40	40	151	36	45-3/4	1,162 mm	20-1/2	520.7 mm	26-1/2	673.1 mm	5-3/4	146.05 mm	190	86.2
DSE-50	50	189	90	54-3/4	1,391 mm	20-1/2	520.7 mm	26-1/2	673.1 mm	5-3/4	146.05 mm	221	100.2
DSE-65	65	246	90	54	1371.6 mm	26-1/2	673.1 mm	33-1/2	850.9 mm	7	177.8 mm	280	127
DSE-80	80	303	90	52-1/4	1320.8 mm	28	711.2 mm	35	889 mm	7	177.8 mm	285	129.2
DSE-100	100	379	90	60-1/2	1524	28	711.2 mm	35	889 mm	7	177.8 mm	354	160.5
DSE-120	120	450	90	65-1/2	1524	30	762 mm	37	939.8 mm	7-1/2	190.5 mm	420	190.5



Commercial Electric Water Heaters

RECOVERY CAPACITIES

Standard kW Input	BTU/ Hour	30°F Rise	40°F Rise	50°F Rise	60°F Rise	70°F Rise	80°F Rise	90°F Rise	100°F Rise	110°F Rise	120°F Rise	130°F Rise	140°F Rise
3	10,239	41	31	24	20	17	15	13	12	11	10	10	9
6	20,478	82	62	49	41	35	31	27	25	22	21	19	18
9	30,717	123	92	74	62	53	46	41	37	34	31	28	26
12	40,956	164	123	98	82	70	61	55	49	45	41	38	35
15	51,195	205	154	123	102	88	88	68	61	56	51	47	44
18	61,434	246	184	148	123	105	92	82	74	67	62	57	53
24	81,912	328	246	197	164	140	123	109	98	90	82	76	70
30	102,390	410	308	246	205	176	154	137	123	112	103	95	88
36	122,868	492	369	295	246	211	184	164	148	134	123	113	105
45	153,585	615	461	369	307	263	230	205	184	168	154	142	132
54	184,302	738	554	443	359	316	277	246	221	201	185	170	158
60	204,780	819	615	492	410	351	307	273	246	223	205	189	176
75	255,975	1025	768	615	512	439	384	341	307	279	256	236	219
90	307,170	1229	922	738	615	527	461	410	369	335	307	284	263

STANDARD kW INPUTS

Standard kW Ratings	Immersion Heaters***		Number of 50A Contactors			Full Load Current in Amperes						
	No. of	Wattage	208V	240V	480V	Single Phase				Three Phase		
						208V	240V	277V	480V	208V	240V	480V
3	1	3,000	1	1	1	14.4	12.5	10.8	6.3	8.3	7.2	3.6
6	1	6,000				28.8	25	21.2	12.5	16.7	14.4	7.2
9	1	9,000				43.3	37.5	32.5	18.8	25	21.7	10.8
12	1	12,000				57.7	50	43.3	25	33.3	28.9	14.4
15	1	15,000				72.1	62.5	54.2	31.3	41.6	36.1	18
18	*1	18,000	2	2	1	86.5	75	65	37.5	50	43.3	21.7
24	2	12,000				115.4	100	86.6	50	66.6	57.7	28.9
30	2	15,000				144.2	125	108.3	62.5	83.3	72.2	36.1
36	*2	18,000	3	3	2	173.1	150	130	75	99.9	86.6	43.3
45	3	15,000				216.3	187.5	162.5	93.8	124.9	108.3	54.1
54	3	18,000				N/A	225	194.9	112.5	149.9	129.9	65
60**	4	15,000	4	4	2	N/A	250	216.6	125	166.7	145	72
75**	5	15,000	5	5	3	N/A	N/A	N/A	156	208.4	181	90
90**	5	18,000				N/A	N/A	N/A	188	250	217	108

* 208V models use one additional immersion heater.

** Available on 50 gallon models or larger.

*** Each immersion heater contains three electric elements.



Commercial Electric Water Heaters

OPTIONAL EQUIPMENT & CONSTRUCTION

GOLDENROD® ELEMENTS

- All DSE models are available with the patented Goldenrod 24K gold plated elements. Goldenrod Elements provide long-life and five times the scaling resistance of standard incoloy elements. Goldenrod Elements carry a three-year warranty against failure due to scale.

STAINLESS STEEL TANK

- Available for deionized water. Add a D to the end of the model prefix for use with deionized water. For example a DSE5 would become a DSED5.

(Please note: Stainless Steel units are deionized water heating applications only! DSED models are not approved or certified for domestic potable water heating applications. To maintain warranty for domestic potable hot water heating applications use on the DSE glass-lined models.)

150 OR 160 PSI WORKING PRESSURE

- Available when required. Must be specified at time of order.

HANDHOLE CLEANOUT – 4" X 6" SIZE.

COMBINATION TEMPERATURE/PRESSURE GAUGE

DIAL TYPE COMBINATION GAUGE (SHIPPED LOOSE).

CONTROL OPTIONS

OVERRIDE SWITCHES

A SIMPLE FORM OF LOAD CONTROL ALLOWS ALL OR PART OF UNIT INPUT TO BE CONTROLLED MANUALLY.

- Up to one override switch per contactor is available.

INDICATING/PILOT LIGHTS

- For indicating element operation and/or switch closure. Up to one indicating light available for each switch and/or contactor is available.

MODULATING CONTROL

- The first element on is the first element off.
- Not available on single element, single contactor units.

PRESSURE LIMIT SWITCHES

- Both high and low pressure limit switches available.

POWER CIRCUIT FUSING

- Sub-divides internal circuitry with maximum of 60 amp fuses. Supplied as standard when required by NEC and UL.

ALARM HORN

- Horns may be furnished to warn of any condition in the heater for which sensors have been specified.

OPTIONAL INTERNATIONAL VOLTAGES

- 380, 415, 575 and 600 volts three-phase available with Y connected elements.

MANIFOLD KITS

- Two Heaters – 9003429205
- Three Heaters – 9003430205
- Four Heaters – 9003431205

SPECIFICATION

The heater shall be a glass-lined Custom Xi™ commercial electric model No. _____ with _____ gallons storage, as manufactured by A. O. Smith. Heater should be rated at _____ kW, _____ volts, _____ phase, 50/60 cycle AC and constructed in accordance with ASME Code, shall bear appropriate symbol and be listed with the National Board as required. Heater shall be listed with Underwriters' Laboratories and approved to The National Sanitation Foundation Standard No. 5. All internal surfaces of the tank shall be glass-lined with an alkaline borosilicate composition that has been fused-to-steel by firing at a temperature of 1600°F. Tank shall be cathodically protected with powered anodes. The entire vessel is to be enclosed in a round steel enclosure with baked enamel finish. Water heater shall have an electronic control with large LCD displaying current water heater status; provide real time element status and sensing, low water cutoff and economy mode operation. Shall have 120 volt control circuit transformer, transformer fusing, magnetic contactor(s), element fusing per N.E.C., and commercial grade incoloy sheathed flange or gold mounted elements with prewired terminal leads. Temperature controls include limiting switch which will require resetting manually in the event the temperature reaches 190°F. Foam insulation shall meet the thermal efficiency and/or standby loss requirements of the U. S. Department of Energy and current edition of ASHRAE/IESNA 90.1. Heater shall include a CSA Certified and ASME Rated T&P relief valve and drain valve.

Water heater should incorporate the iCOMM™ system for remote monitoring, leak detection and fault alert.

For technical information, call 800-527-1953. A. O. Smith Corporation reserves the right to make product changes or improvements without prior notice.